

A Zigbee Based Wireless Sensor Network for Sewerage Monitoring

Abstract —

Blockages in sewers are major causes of both sewer flooding and pollution. Water companies which fail to tackle this problem face hefty fines and high operational costs if they are unsuccessful to provide a practical solution to prevent flooding. As a result, the detection of sewer condition is routinely required to inform on the best course of action to eliminate this critical problem. This paper presents a novel low cost wireless sensor technology to detect blockages proactively, and feed these event data back to a central control room. The practical deployment of the proposed WSN in an urban area will be demonstrated. In addition, the challenges of this technology in a field trial and the recorded data in terms of the sensor and communication reliability will be addressed

Server unit

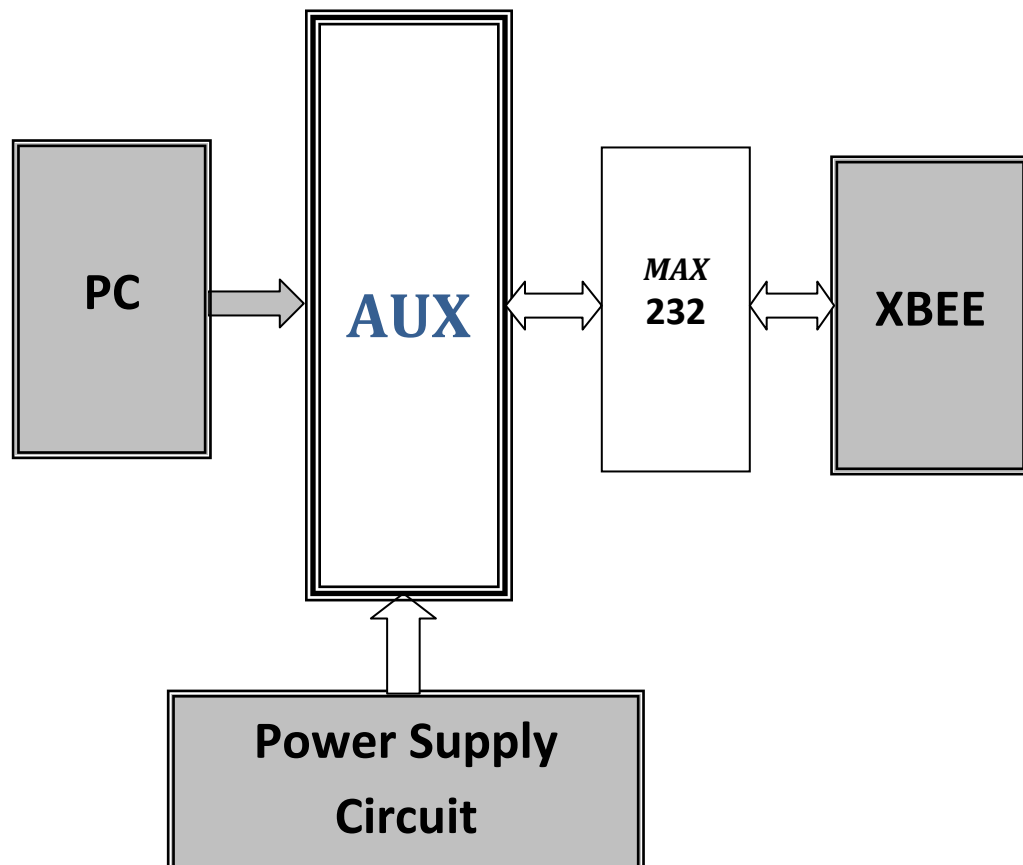

Sump block Sensing Circuit(2)

