

Comm/Nav Multi Processor System

Aim: This system is used to control and monitoring the communication transceiver/navigation receiver with optional glide slope receiver and optional audio amplifier in the Aircraft.

Description:

This system consists of 4-modules,

1. Frequency monitoring and Control modules.
2. LCD Display of each Comm., NAV.and radial information, use and Standby frequency.
Digital keypad for auto tuning and audio control Section.
3. DME Monitoring and control module
4. VOR/LOC radial monitoring module

Overview of projects:

The AUX is connected to Decoder, Latches, LCD, LED Display Unit, and Keypad. This system contains five different units, like DME, COMM, NAV, VOR/LOC, and Glide Slope Units. Auxiliary is Communicate to all these units by address and data bus. First address will select for the I/O units, ie) to enable the address of latch then send or receive the data's.

All the I/O data to display on the LCD display. We will receive all frequency from all units and compare the frequency to then auto tune and display the USE and Standby frequencies. Each data communication is based on 8-bit communication. The address is in 3-bit communication. The control and communication is designed by scheduling concepts.

This system will maintain the different frequencies in different unit data communication. Each unit is monitoring by the main control unit then it will display on the LCD. The keypad is used to read the input data and set/control the frequencies level.

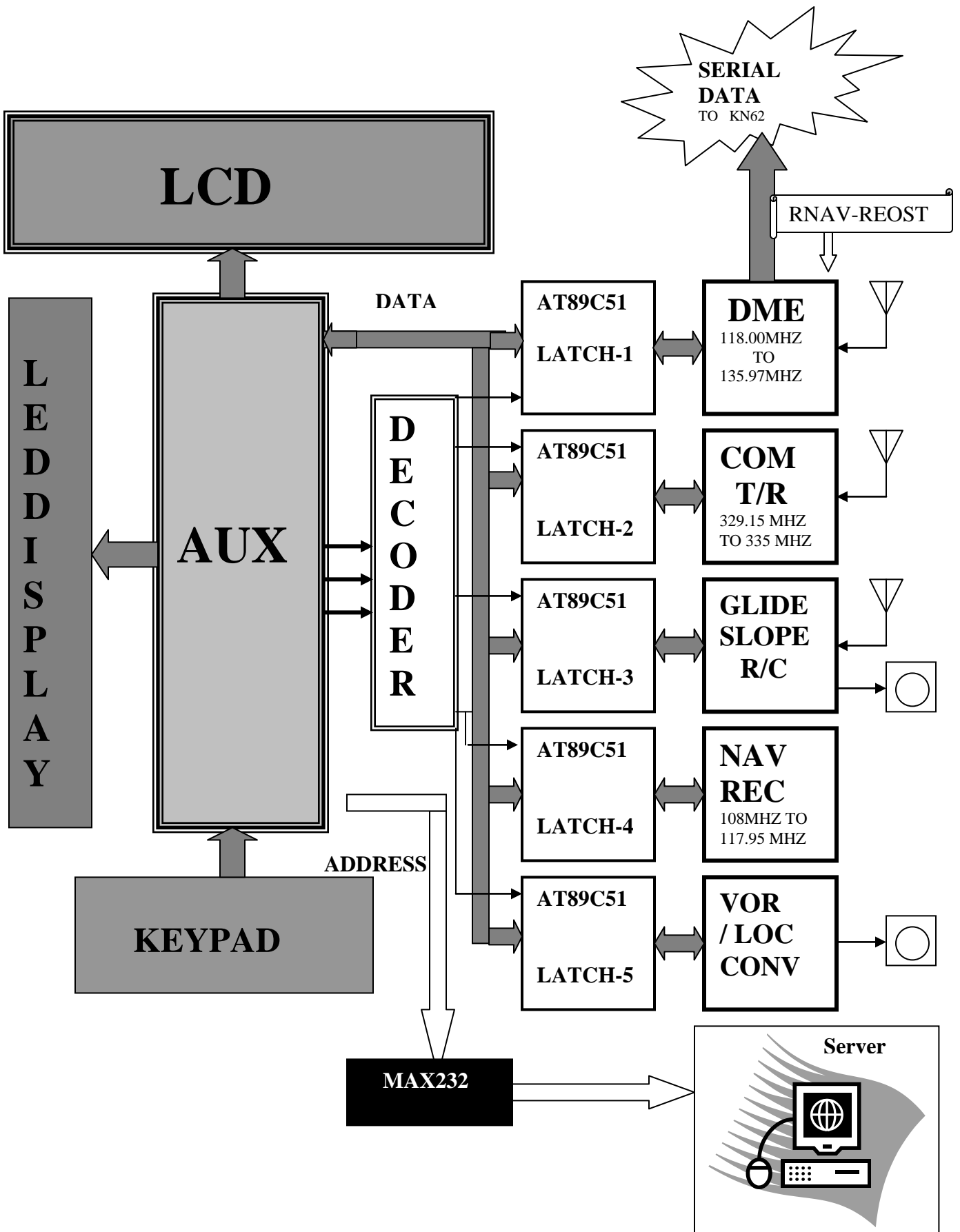

1. Frequency monitoring and Control modules.

1. Communication transceiver which operates 118.00MHZ to 135.975MHZ
 - ✿ Frequency sensing Section
 - ✿ Control and Monitoring Section
 - ✿ Auto tuning of 25KHZ of frequency and total tuning of 720 Channels.
2. Navigation receiver for VOR/LOC Signals from 108.00MHZ to 117.95MHZ
 - ✿ Frequency sensing Section
 - ✿ Control and Monitoring Section
 - ✿ Auto tuning of 50KHZ of frequency and total tuning of 200 Channel.
3. Glide slope receiver operating from 329.15MHZ to 335.00MHZ
 - ✿ Frequency sensing Section
 - ✿ Control and Monitoring Section
 - ✿ Auto tuning of 150KHZ of frequency and total tuning of 40 Channel.

This section will sense/receive the frequency level from the aircraft and auto tune this frequency to a given sector levels (25KHZ). Then auto set the frequency and communicate to the particular aircraft. USE and STANDBY freq. Is to auto tuning and stored it in internal memory.

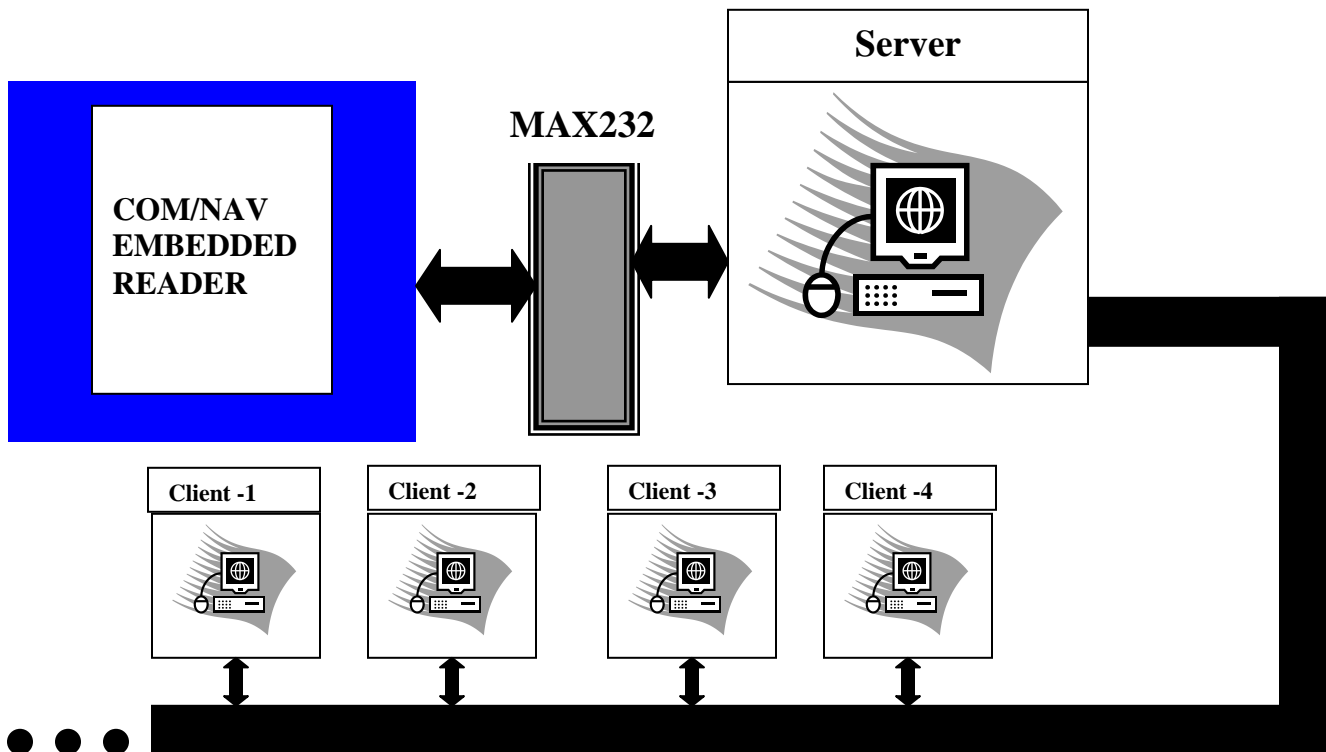





2. LCD Display of each Comm., NAV.and radial information, use and Standby frequency.
Digital keypad tuning for auto tuning and audio control Section.

- All frequencies and display on the LCD Display.
- We will display of 4 different Channel frequencies.
- Each information is display on the LCD display.
- This Keypad for to get the input keys from this keypad
- Keypad contains 4x4 matrix keys (16-keys)
- The main keys are auto tune, numerical, Inc, Dec, set, reset keys.

4X4 - LCD DISPLAY

COMM : 123.50	STBY : 118.00
NAV : 113.00	STBY : 117.80
VOL : *****	CHAN : 1
VOR : 65 DEGREE	

4X4- KEYPAD

VOR	NAV	GLD	DME
TIM	MOD	V+	V-
T+	T-		
		SET	ENT

VOR : To select VOR synthesizer frequencies

NAV : To select NAV synthesizer frequencies

GLIDESLOPE: To select GLIDESLOPE synthesizer frequencies

DME : To select DME synthesizer frequencies

TIM : To select Timer mode

MOD : To select Mode for COMM \ NAV

V+ : To increment Volume of Head Phone

V- : To decrement Volume of Head Phone

T + : To increment by auto tuning

T - : To decrement the auto tuning

UP : Move the cursor to pervious row on the LCD

DOWN : Move the cursor to next row on the LCD

RIGHT : Move the cursor to next column on the LCD

LEFT : Move the cursor to pervious column row on the LCD

SET : To set the standby frequency

ENT : Go to next cycle

LED DISPLAY

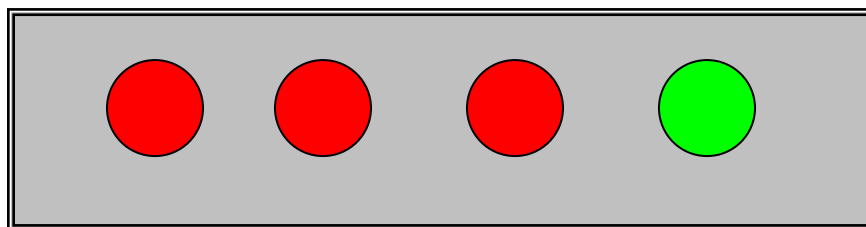

POWER

DIMMER

ALARM

SIGNAL

POWER : Power for this system

DIMMER: strength of Signal

ALARM : Alert to Safety / failure of system

SIGNAL : ON / OFF

Advantage of these Systems:

- 1) Automation of all CUSTOM to communicate through remote Aircraft by COM/NAV System
- 2) Save data using automatic control systems
- 3) Less cost to communicate
- 4) Less power to automate
- 5) Increase productivity
- 6) To increase n number of Aircraft to communicate simultaneously and automate.
- 7) Easy and fast Communicate the system
- 8) Avoid more Accident of Aircraft
- 9) Multi OS Communication

Feature of these system:

- 1) To automate all Aircraft to communicate by auto rout planning of Communication.
To modify this system into Auto Route design of COM/NAV.