

Wireless Unmanned Tanker Robot

Aim: This project aims at designing control system for a robot such that the unmanned vehicle is controlled using PC and wireless RF communication. In this project the controlling is done depending on the feedback provided by the IR sensor, which is the part of object detection circuit.

Description:

The project contains different modules such as

- Object detection and angle determination in the path using IR sensor.
- Obstacle avoidance and enemy detection.
- Design of RF circuits for data transfer.

In the object detection module when the AT89c2051 micro controller is powered up the stepper motor starts rotating at 360-degree arc. The IR sensor is mounted on stepper motor. When an object is detected by the IR sensor the microcontroller stops the robot and stepper motor.

The IR sensor consists of IR transmitter and receiver .the IR transmitter is a led and receiver is detected the object and receive the IR pulse. Here the frequency used is 38 kHz. The angle detected is sent to PC using RF communication. The rotation of each step is calculated in to each step. From PC keyboard to control the speed, left and right control key value is sending through Serial port. The serial port is connected into RF Encoder circuits and RF Transmitter.

The data transmission is happened in 4-bit communication. PC key entering value is sending to RF. The value will receive into the RX-RF and compare of each value and control all steps. But IR it will work under object detection and controller will shoot .

In the RF circuit design two pairs of RF transmitter and receiver are used. One set is used for communication between AT89c2051 micro controllers.

Overview of Embedded C

The C programming language is a general-purpose programming language that provides code efficiency, elements of structured programming, and a rich set of operators. C is not a *big* language and is not designed for any one particular area of application. Its generality combined with its absence of restrictions, makes C a convenient and effective programming solution for a wide variety of software tasks. Many applications can be solved more easily and efficiently with C than with other more specialized languages.

The **Cx51** Optimizing C Compiler is a complete implementation of the American National Standards Institute (ANSI) standard for the C language. **Cx51** is not a universal C compiler adapted for the 8051 target. It is a ground-up implementation dedicated to generating extremely fast and compact code for the 8051 microprocessor. **Cx51** provides you with the flexibility of programming in C and the code efficiency and speed of assembly language.

The C language on its own is not capable of performing operations (such as input and output) that would normally require intervention from the operating system. Instead, these capabilities are provided as part of the standard library. Because these functions are separate from the language itself, C is especially suited for producing code that is portable across a wide number of platforms.

Since **Cx51** is a cross compiler, some aspects of the C programming language and standard libraries are altered or enhanced to address the peculiarities of an embedded target processor.

Block Diagram of PC Control Unit:

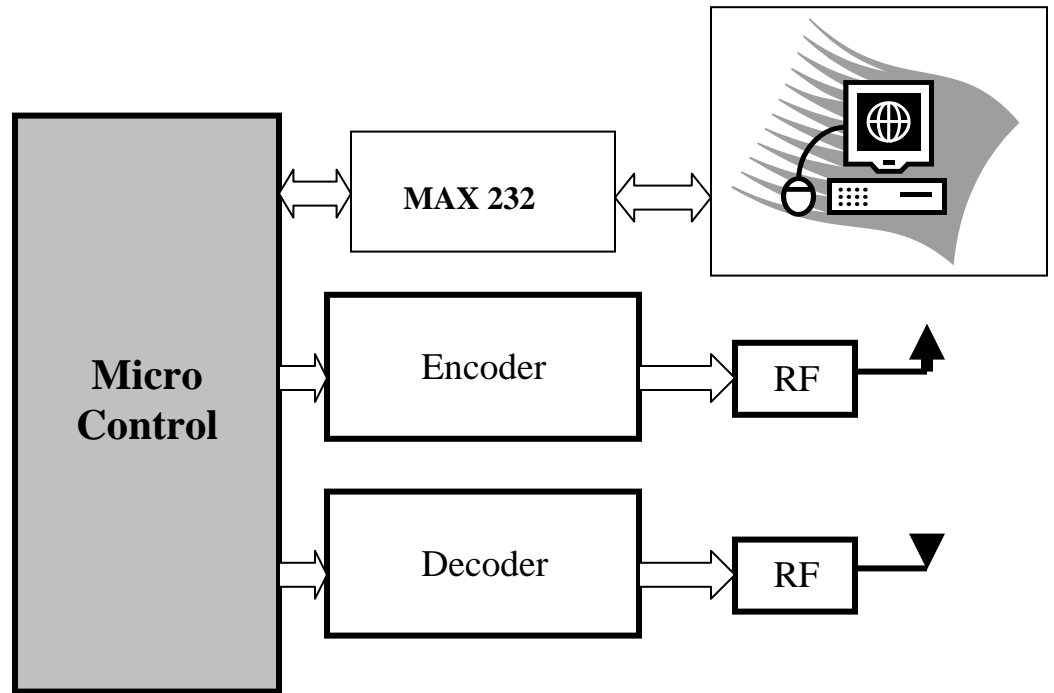

BLOCK DIAGRAM OF VEHICLE CONTROLLER CIRCUITS:

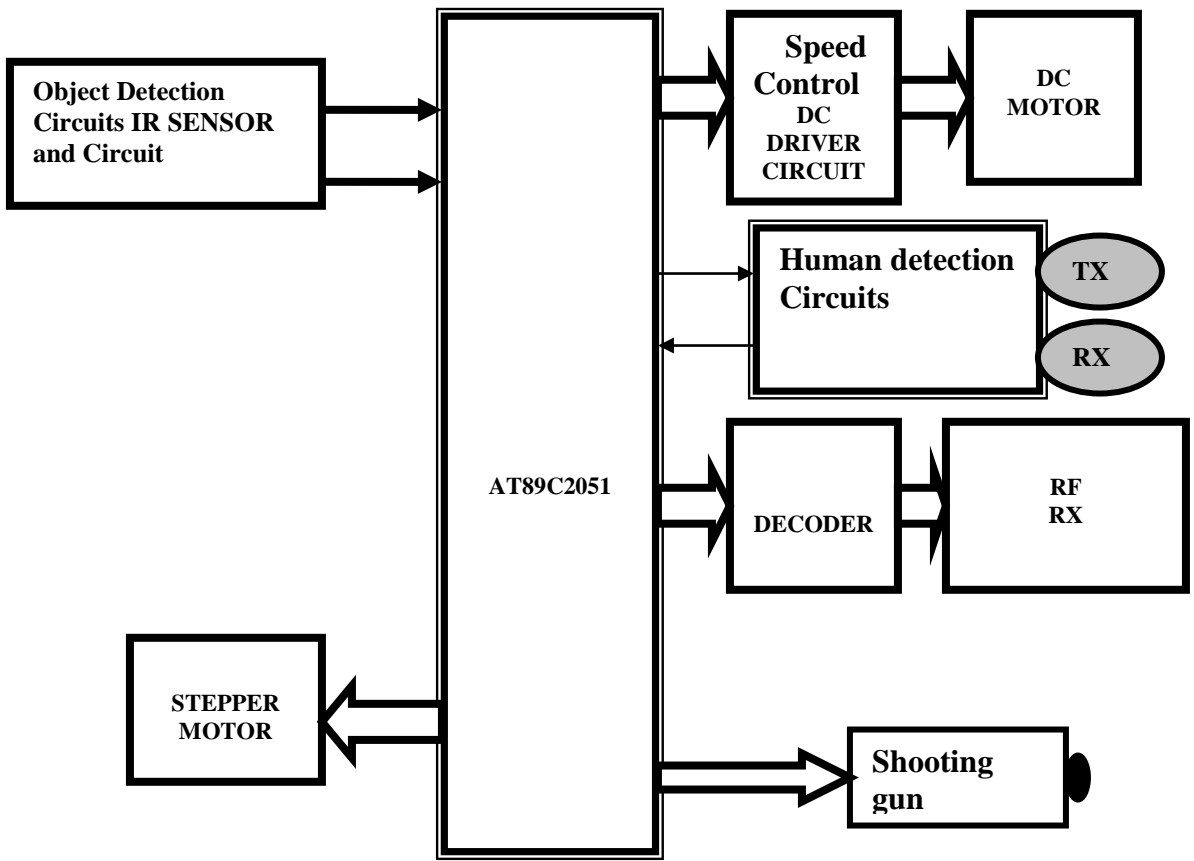

RF ID:

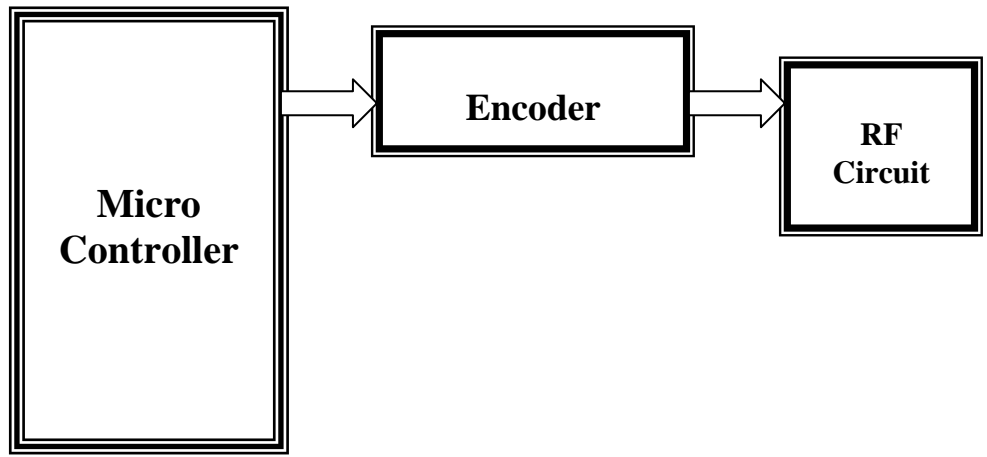

Here will store ID number then always will send the ID value through RF TX in 433MHZ frequency.

Start Bit-1	Data – 8 Bit	Stop Bit - 1
--------------------	---------------------	---------------------

Frame format of RFID

Application:

- 1) Military (Army)
- 2) Industrial Automation

Advantages:

- 1) Moving Object Detection of Enemy and Obstacle.
- 2) Auto Detect and Shooting
- 3) Angle Detection
- 4) Speed Control
- 5) RFID for Enemy detection
- 6) Compact Vehicle
- 7) Real Time mode.

Future of this System:

- 1) Image Process of Enemy detection
- 2) Path finding and Tracking