

GSM Autonomous CAR Parking With Image Processing

Introduction:

In this car parking system, where the arrival of the car is detected automatically and the door is open for the car. Car number is identified by image processing and the billing is done. IR and RF is used for object detection and data transmission.

Objectives:

This project has 3 modules. One is placed in entrance of the gate. The second module is placed in the parking floor. The third is present at the billing section.

In the first module once the car comes in the entrance it is detected. This is performed using IR. Then the gate is open for it to enter. In the entrance LCD is present which shows the availability of the parking place. It helps the persons to park his car in the available place.

The second module is present in the parking area. Once the car is parked, it is identified and the slot number where the car is parked is transmitted to the billing section, to the entrance and to the stepper motor controller. Accordingly the stepper motor is turned to its position and the number plate is captured. The availability of the parking place gets updated every time a car is parked. The image is then processed and transmitted to the billing section.

Third module is the billing section. Here the video image is received and the number of the car is identified and is recorded. The slot number is also get through the RF receiver. The bill is prepared for that car. Here the mobile is interfaced with the computer. From the PC the message is transmitted to the head office using GSM protocol for recording the data.

PC RECEIVER of GSM with RF BLOCK DIAGRAM:

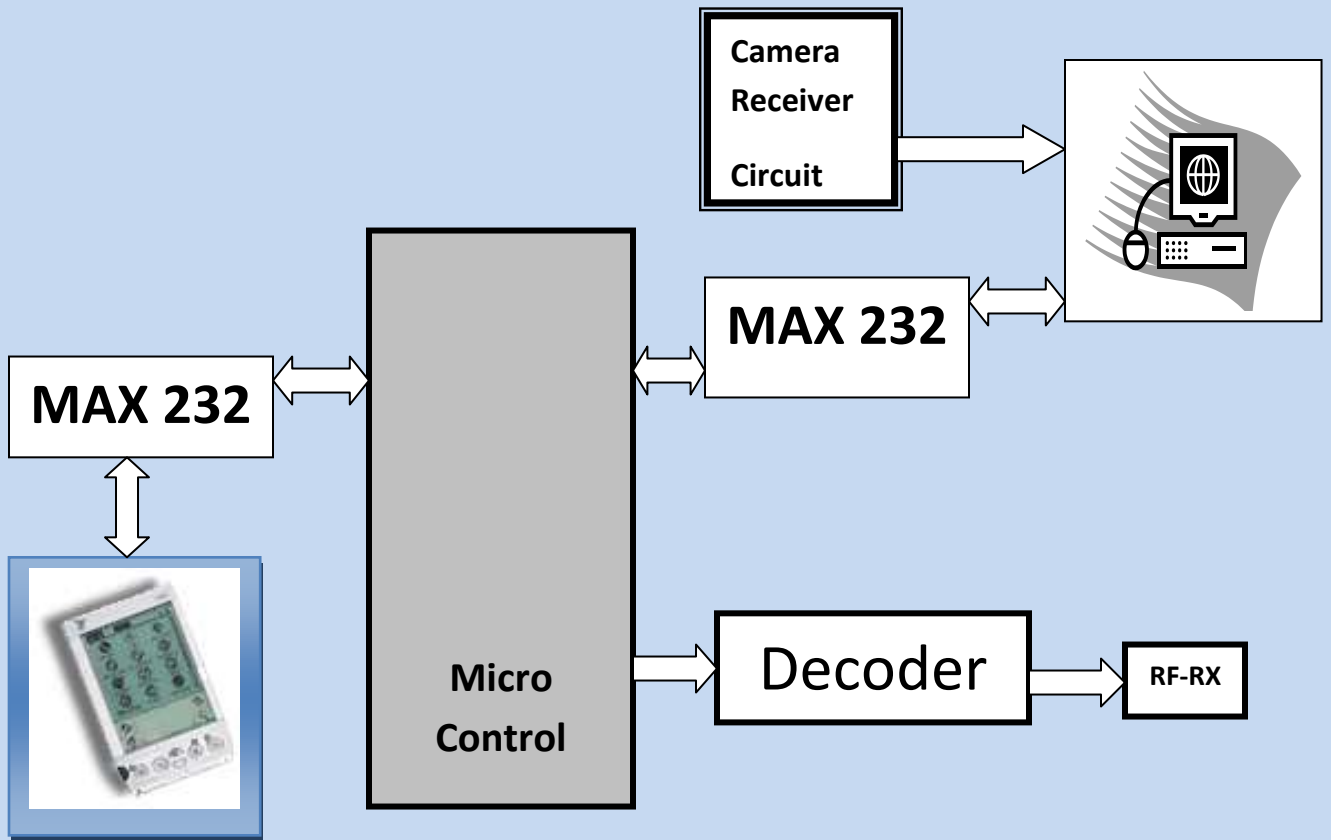

Block Diagram of Gate Display Wireless Camera:



Block Diagram of Slot Sensing RF Circuit:

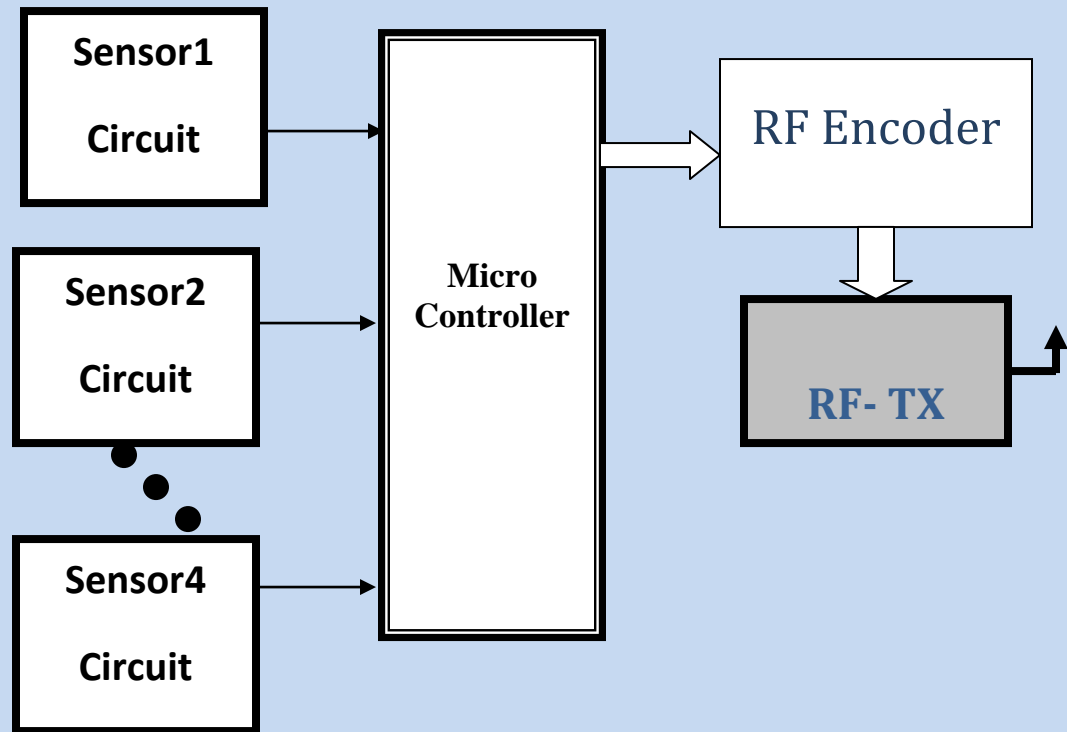

Methodology of this Project:

1. GSM (Fbus Protocol)
2. RF Communication-433MHZ
3. IR – 38KHZ
4. Image Processing in Mat lab
5. PC RS232 Communication