

GSM Multi Machine Remote Debugger Systems

Aim:

This system is used to find the Error of each Machine and save the machine status in PC using wireless Communication and reply all error status to send owner mobile using GSM for Industrial Automation.

PC Data Base Module:

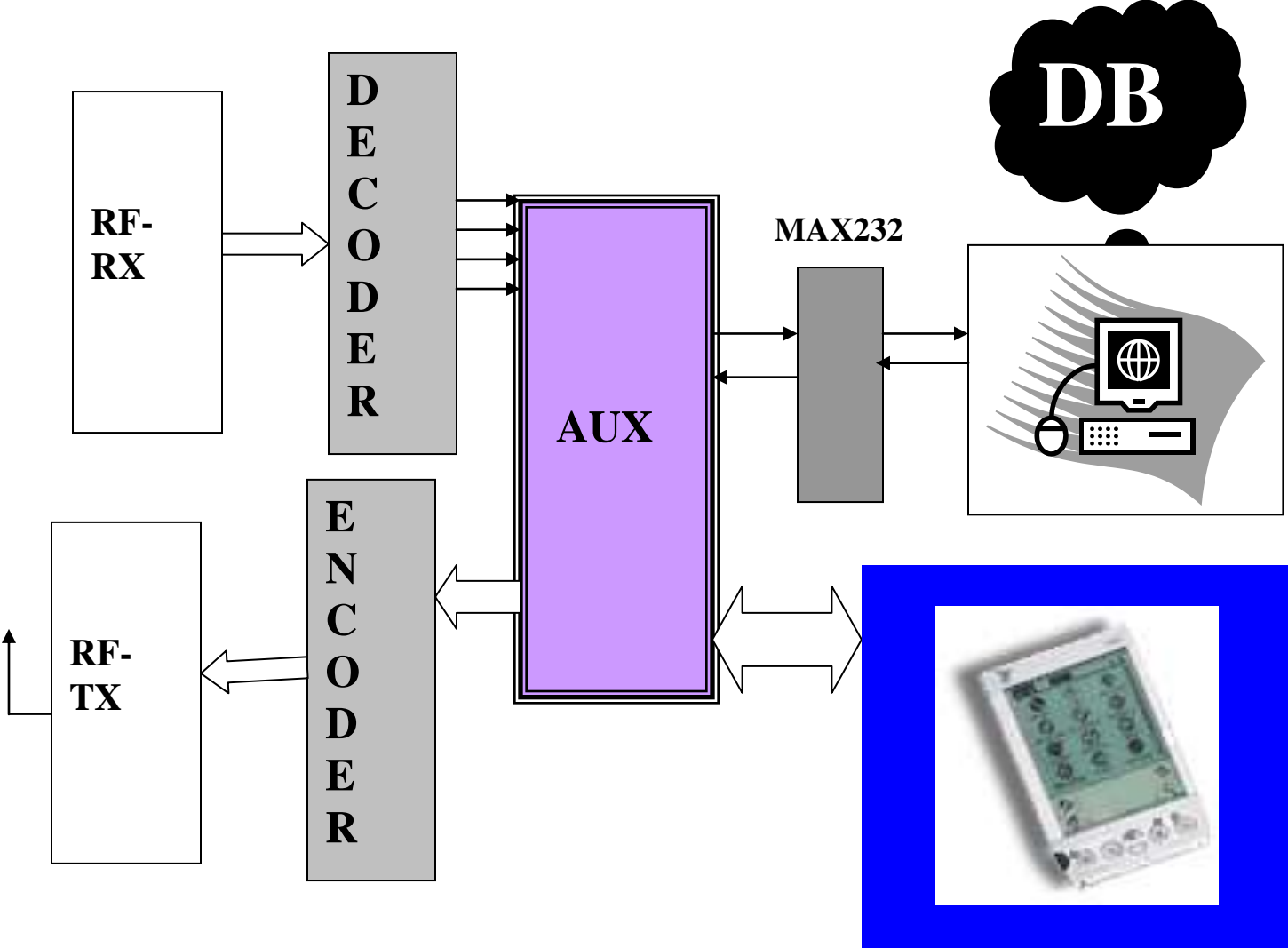

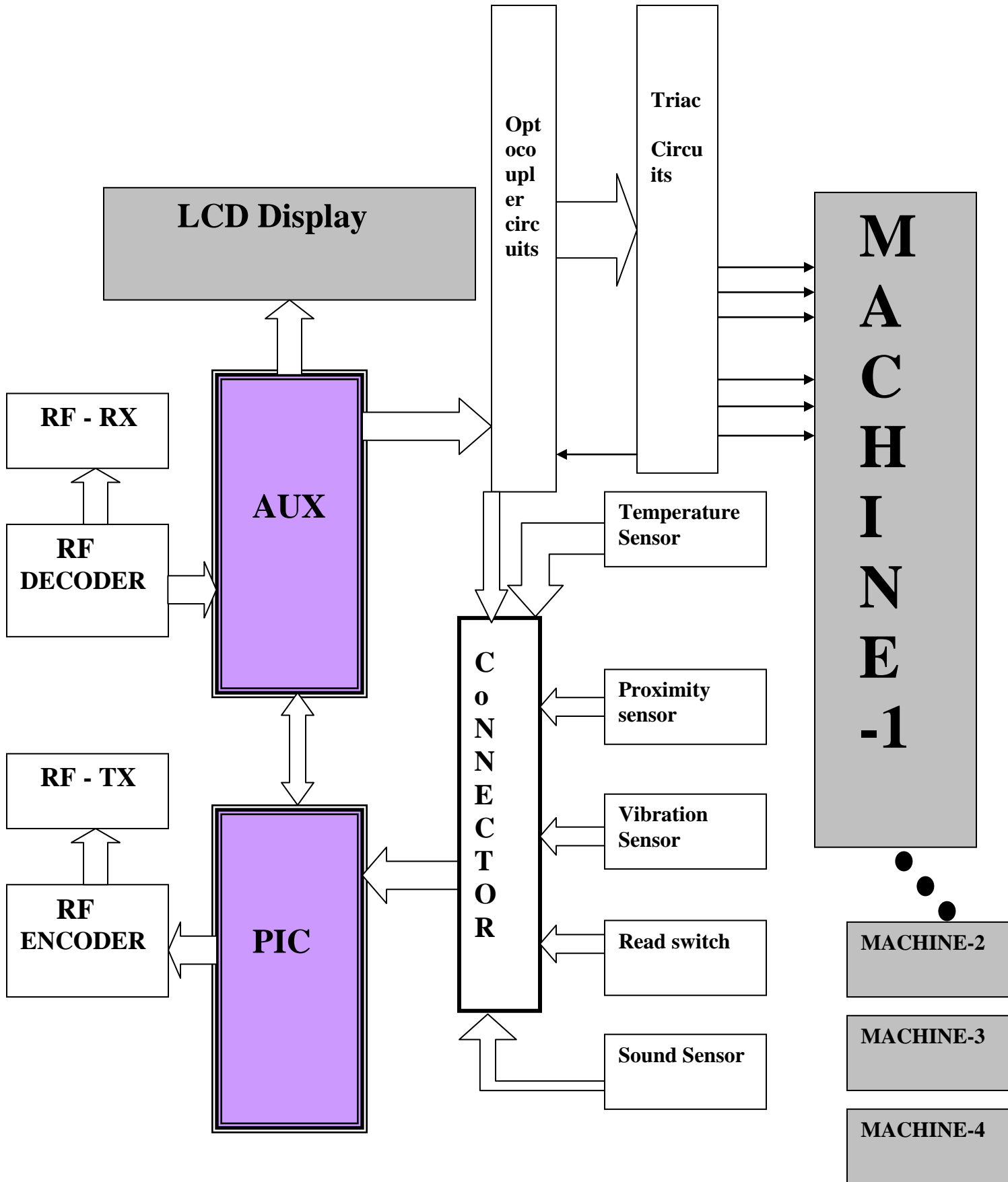

Description:

This Monitoring and Control system having three different modules,

- 1) Read Status of each machine for RF
- 2) GSM
- 3) PC -Data Base Storage System

Wireless Control System

1) Controller for RF and Machine

This is divided into two different modules,

- a) Serial Communication
- b) Driver for four machine power and Relay/machine control
- c) RF Communication

2) PC:

This is divided into three modules,

- a) RS232 communication,
- b) Display module
- c) Data Base Storage System

3) GSM

This system is used to read and control the data from all four machines. Then for each day all data's are sending into PC via RF communication. The PC will receive all data and display on the screen and stored in DB using C.

At the same time the controller will send the data (Status) into owner mobile via GSM communication.

Criteria:

The control system will support more than 4 machines.

This process continues for every day.

Input:

The control set into SMS via mobile using GSM to microcontroller.

- 1) Set Password from your mobile on 4 Digit
- 2) Machine Number – 2 Digit
- 3) Start – Time – 4 Digit
- 4) Stop Time - 4 Digit
- 5) Types of Error using Digital values.

Output:

You can get all machine status from your mobile.

Machine Number, Time and Start / Stop - 6 Digit

Displays:

- Machine number
- Status, starting time
- Total days, total Duration of Machine executed.
- Option to select which machine should get tripped.

Select Machine to start / stop Error,

2. Machine 1
3. Machine 2
4. Machine 3
5. Machine 4

Advantage of these Systems:

- 1) Automation of all machine through remote place using mobile
- 2) Save Energy using automatic control systems
- 3) Less cost to communicate
- 4) Less power to automate
- 5) Increase productivity
- 6) To increase n number of machines can automate.

Feature of these system:

- 1) To automate machine error testing and debugging through mobile via SMS Communication.
- 2) Secure this system through GSM technologies. (To read the data from your mobile)