

Gsm Based Patient Monitoring System

Aim:

Monitoring the patient's condition can be done by using biomedical telemetry method where there is a mobile communication between microcontrollers. The temperature, heart beat and blood pressure are all sensed by using the appropriate sensors which are placed near the patient's body that is under investigation.

Description:

The biomedical telemetry system consists of temperature sensor, heart beat sensor, pressure sensor, A/D converter, signal conditioning circuit, microcontroller, data cable, mobile phone, LCD display. The temperature sensor is used to sense the temperature value of the patient's body. The sensed output is given to A/D converter where the analog signal is converted to digital signal. The digital output is given to microcontroller. The microcontroller delivers the signal for mobile phone through data cable. Then the signal is transmitted to other mobile through GSM network. The receiver mobile receives the signal and it is given for a PC. The signal from data cable is given to PC and the value gets displayed using monitor. The pressure sensor is used to sense the pressure value of the patient's body. The sensed output is given to A/D converter where the analog signal is converted to digital signal. The digital output is given to microcontroller. The microcontroller delivers the signal for mobile phone through data cable. Then the signal is transmitted to other mobile through GSM network. The receiver mobile receives the signal and it is given for a PC. The signal from data cable is given to PC and the value gets displayed using monitor. Heart beat can be sensed by using heart beat sensor which is then given to a signal conditioning circuit. This unit delivers a train of pulses to microcontroller and the value gets displayed using LCD display.

This System is divided into two different modules,

- 1) PC Wireless and storage Unit*
- 2) GSM with microcontroller unit*
- 3) Patent Monitoring RF and Sensor Unit*

1) PC Wireless and storage Unit & GSM with microcontroller unit

This Micro control unit is connected to RF receiver unit with help of GSM and PC Unit.

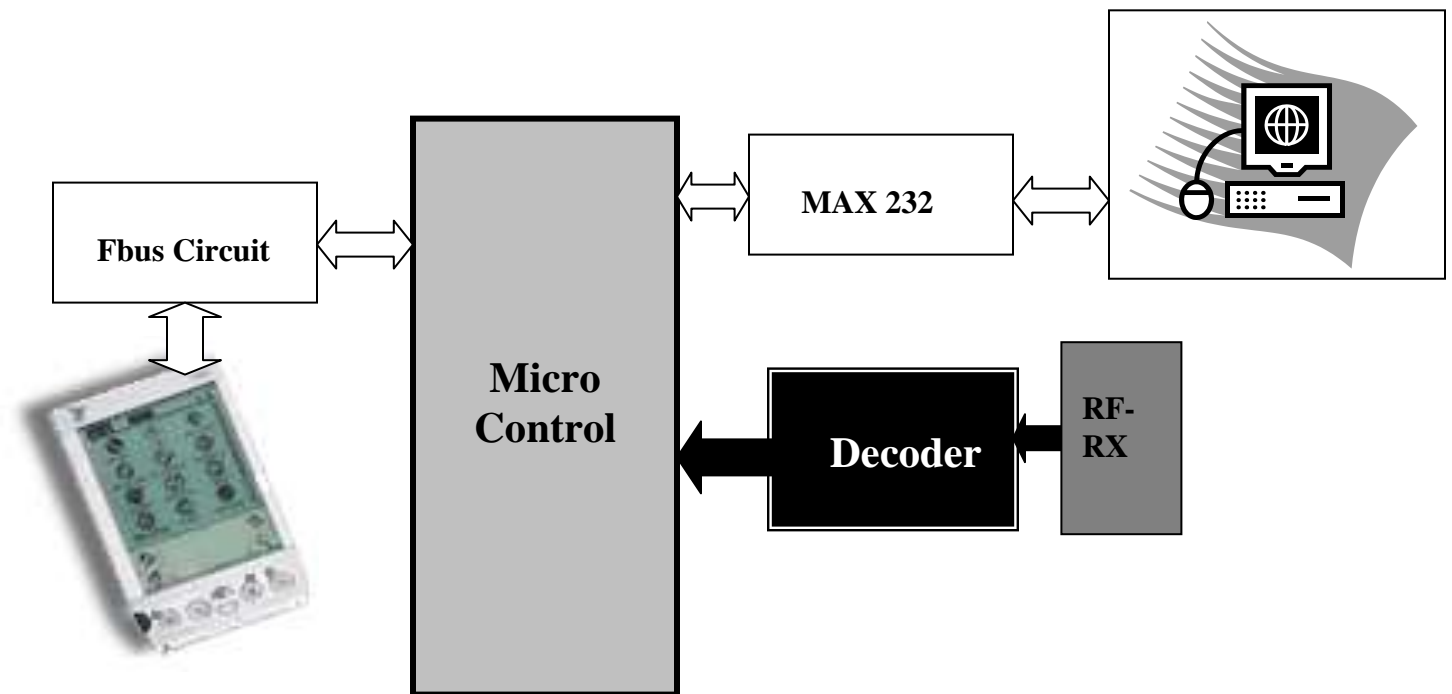

2) Patent Monitoring RF and Sensor Unit:

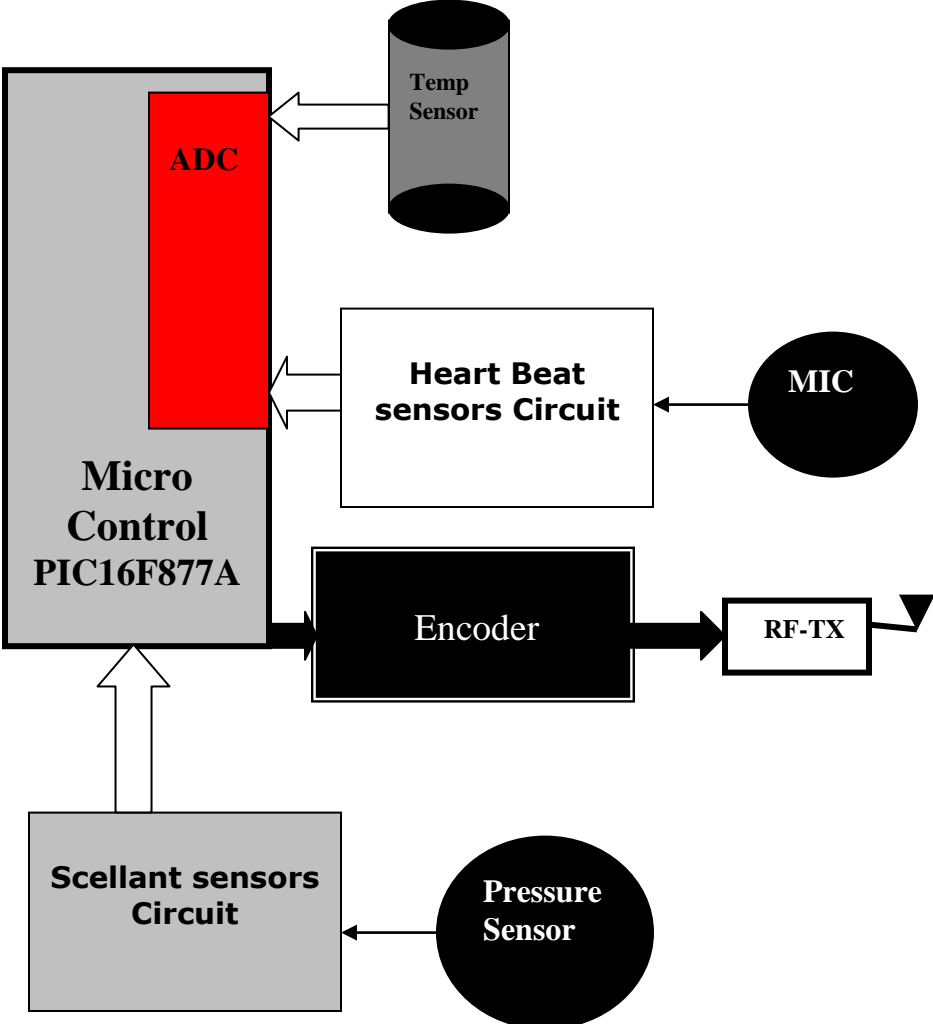

2. Process of this saline System:

- 1) The drip may administer saline solution to the patient to prevent dehydration and increase blood volume or other fluids, such as insulin, blood or gelofusin. The intravenous drip has a bag containing the fluid which is attached to a filter chamber. This leads to a reservoir which has a piece of tubing extending therefrom which feeds fluid through a needle into the vein of a patient.

The drips are checked at regular intervals by nursing staff to ensure that the fluid is still flowing through the apparatus into the patient. This is time consuming for the nursing staff and additionally, results in the patient being disturbed during the night when the nurse has to check that the drip is still working correctly. Some essential fluids are pumped into the patient via the intravenous drip to ensure that the correct amount of fluid is being administered but the majority of fluids enter by means of gravity, with the bag of fluid being positioned above the height of the patient such that the fluid drips down the tubing and is delivered into the vein of the patient. This necessitates careful monitoring of the drip by nursing staff to ensure that sufficient fluid is being administered to the patient.

The signal used in the method and apparatus of the present invention may be infra-red light produced from an infra-red emitter. Alternatively, a red or other light source may be used. Preferably, this signal is transmitted to the intravenous drip by means of an optical fibre.

A through-scan, in the form of a bracket, is preferably provided for placement around a region of the intravenous drip for allowing transmission of the beam across the passageway of the flow of fluid. A further optical fibre is preferably attached to the opposite side of the through-scan to receive the signal transmitted through the passage and deliver the signal to the sensor.

The through-scan in the form of a bracket is preferably hinged to allow easy placement around a region of the intravenous drip, such as the chamber or drip pod. Adjustable fastenings may be provided to fasten the bracket around the intravenous drip. The bracket may be made of any suitable material but preferably is made of a lightweight plastics material.

The sensor is preferably linked to a circuit which has a light emitting diode (LED) which becomes illuminated when the flow of fluid stops. when fluid is flowing through the apparatus and a reduced amount of infra red light is being received by the sensor. which changes to red when the flow of fluid stops. This change is brought about when a predetermined amount has energy has built up over a given period of time, for example 10 seconds, indicating that the infra red signal has not been broken by a drip of fluid, Circuitry may be installed such that the green light flashes with each drip of fluid that passes through the chamber to confirm that the apparatus is working correctly.

when the rate detected by the monitor unit falls within a predetermined tolerance of the set rate, for example + 50%. If the rate falls outside the tolerance level or if no drops are detected within a predetermined period of time, the GSM will send message to Doctor.

The system exhibited a worse case error of 2g in the mass measurement. This allows for the accurate computation of the level of the IV bag but results in significant errors in the flow rate measurement.

The system is also capable of providing warnings if an improper dosage is detected and aims to reduce problems which are a result of human error.

The sensor may be linked to suitable electronic circuitry to allow the number of drops of fluid which are fed from the intravenous drip within a set period of time to be determined, for example drops per minute. Preferably, the number of drops which pass through the apparatus within the set period of time is to send to PC by RF, then compare to the error or result.

3. Process of this Heart Beat System:

The doctor can program the device to send an alert for specific reasons, such as a significant increase in the number of irregular [heartbeat](#) (arrhythmia) episodes, as well as the preferred alert method, i.e., via cell phone.

count your heartbeat for 15 seconds and multiply by four is easiest. For an avg. male it is about 62 beats per minute but closer to 45-50 if you're in really good shape for late teens to mid 20s.

Once you feel your pulse start counting for ten seconds. Multiply that number by 6 and that is your heart rate per minute, or BPM. It should be between 75 and 85 for resting and could get near 200 when active for your age.

4. Process of this Temperature Monitoring System:

Body temperature in a healthy, young person usually falls within 97.5 F (36.2 C) to 98.9 F (37.2). if grater value it will send data to PC by RF Communication.

3. Advantages and feature:

- 1) To Monitor by Wireless Communication
- 2) To secure the data through PC
- 3) Less cost
- 4) IEEE standard GSM Protocol Design