

# MOBI CARE SYSTEM USING GSM

## Aim:

This system is mainly used to communicate the customer and shop using GSM mobile communication in a flexible way.

## Project over view:

This system consists of three modules and listed below

1. Customer.
2. Customer Care.
3. Shop.

\*In this project, customer & customer care are interconnected and customer care is connected with N number of shops. But there is no interaction between the customer and shop. The customer care acts as a mediator.

## Block Diagram:

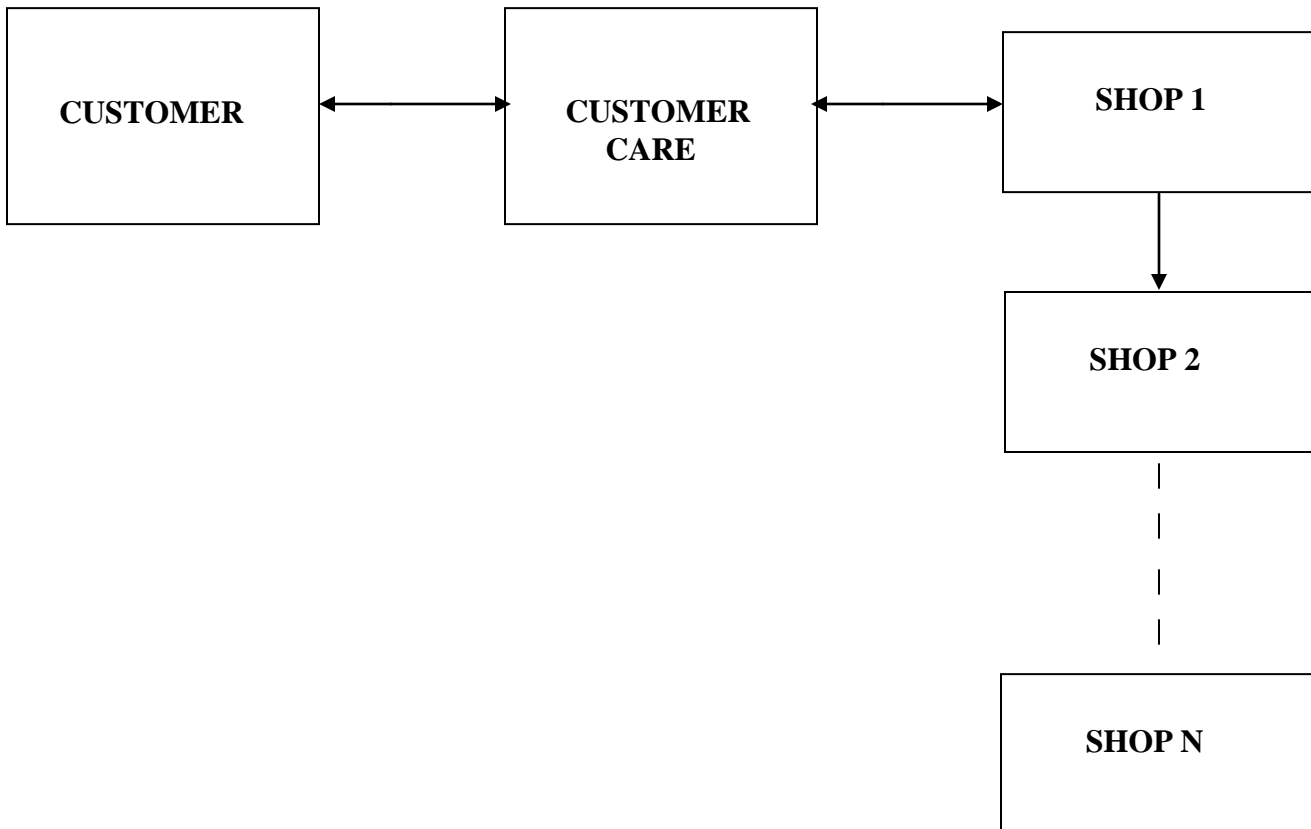

# CUSTOMER CARE MODULE

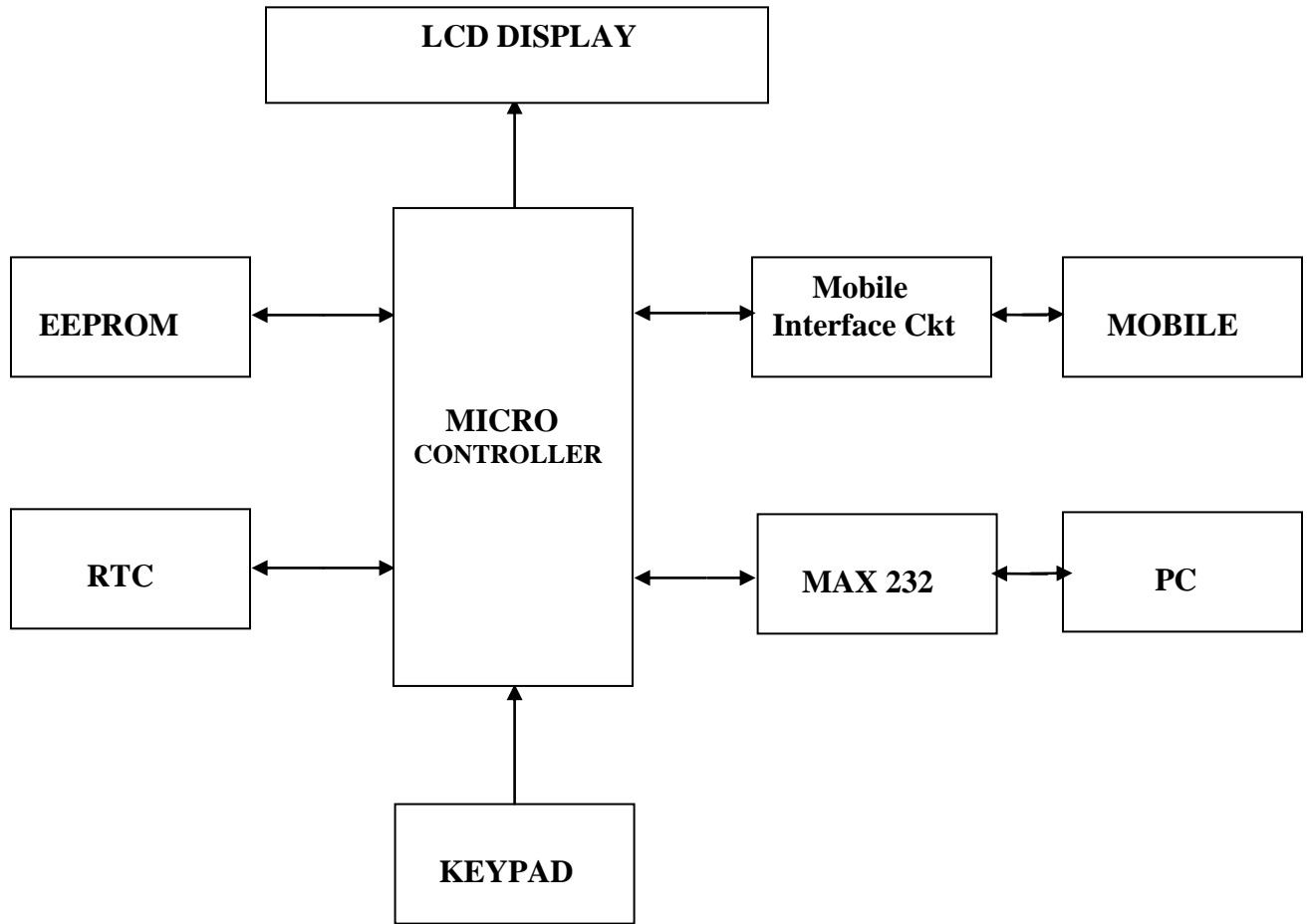

# SHOP

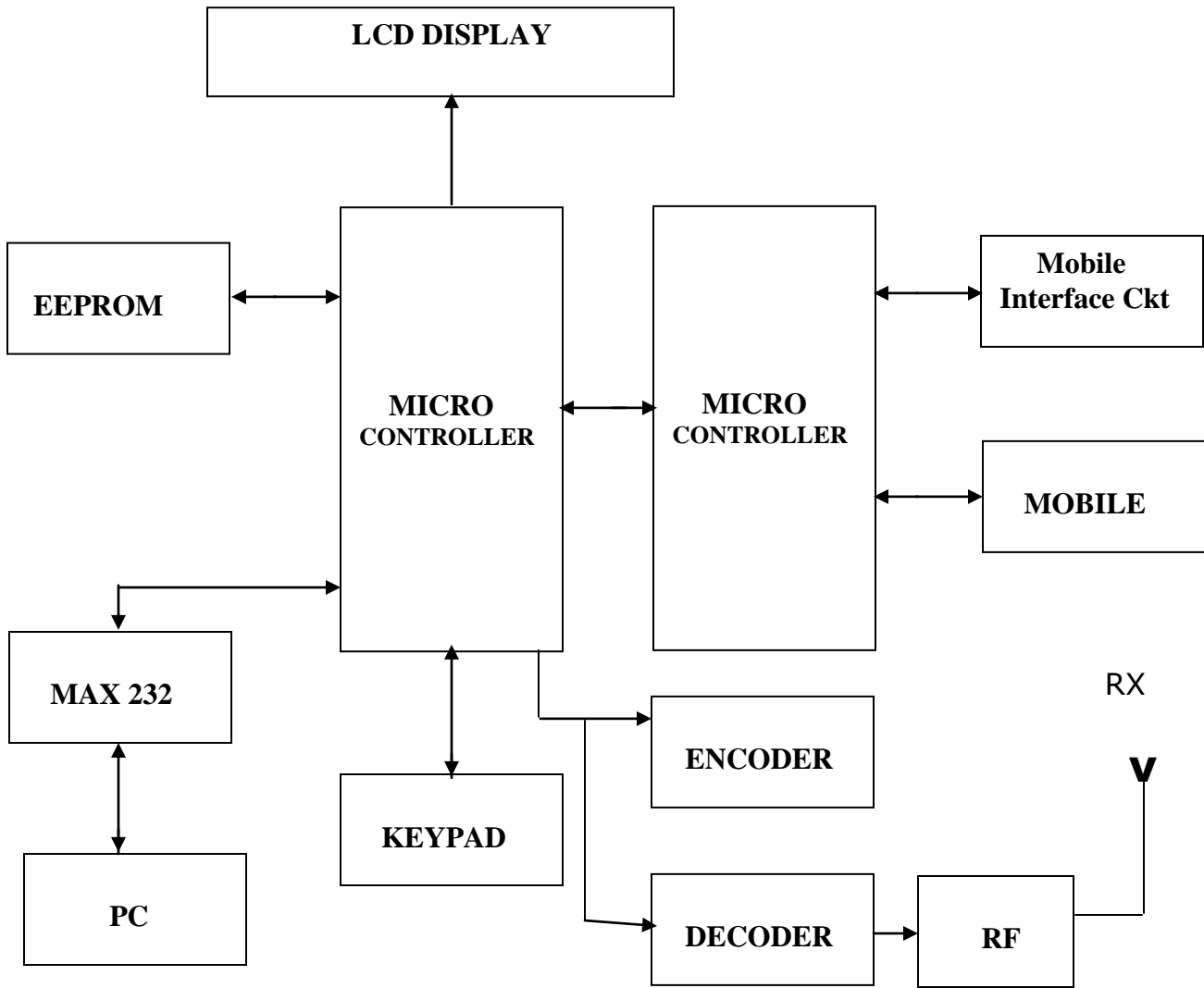

**RF**

**TX**

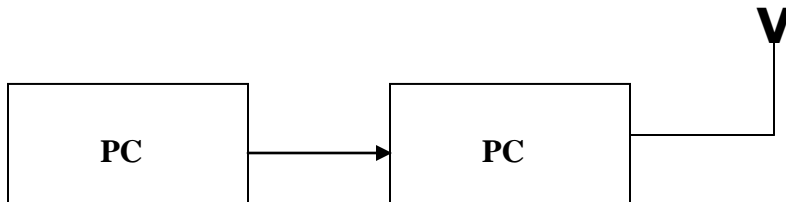

## Description

\*The customer sends the message to the customer care centre .This message should contain the particular valid code.

\*Then the customer care takes care of the message and to take necessary steps to communicate with shops regarding to the customer's requirement.

\*Customer care checks the availability of product in the interconnected shops with the respective code given by the customer.

\*If the particular product is available then the shop will send the below given details to the customer care.

### PART I

1. Name of the product.
2. Product code.
3. Rate of the product.
4. Tax for the product.

### PART II

1. Shop Address.
2. Phone No.

\*Finally the customer care makes contact with the customer and delivers the required product indeed.