

SENSOR BASED MOTION CONTROL OF MOBILE CAR ROBOT

Aim:

To capture any image of the object and send it to the PC using wireless audio and Video communication for any security systems.

Description:

Now a day's mobile robots are vastly used in many industries for performing different activities. Controlling a robot is generally done using a remote control which can control the robot to a fixed distance.

This project aims at designing control system for a robot such that the mobile robot is controlled using mobile and wireless RF communication. In this project the controlling is done depending on the feed back provided by the IR sensor which is the part of object detection circuit.

The project contains different modules such as

- Object detection and angle determination in the path using IR sensor.
- SMS protocol (F-Bus) development.
- Design of RF circuits for data transfer and camera interface.

In the object detection module when the at89c2051 microcontroller is powered up the stepper motors starts rotating at 180 degree arc. The IR sensor is mounted on stepper motor. When an object is detected by the IR sensor the microcontroller stops the robot and stepper motor.

The video camera mounted on the stepper motor starts transmitting the object picture continuously. Here the IR sensor consists of IR transmitter and receiver .the IR transmitter is a led and receiver is Tsop receiver. Here the frequency used is 38 kHz. The angle detected is sent to PIC where it is displayed on the LCD display.

In the SMS protocol development module F-Bus is High-speed full-duplex bus. It uses one pin for transmitting data and one pin for receiving data plus the ground pin. Very much like a standard serial port. It is fast 115,200bps, 8 data bits, no parity, and one stop bit. For F-Bus the data terminal ready (DTR) pin must be set and the request to send (RTS) pin cleared. This F-Bus is used to connect mobile to PIC microcontroller. The commands for controlling the robot are sent by mobile through PIC using RF communication.

In the RF circuit design two pairs of RF transmitter and receiver are used. One set is used for communication between at89c2051 microcontroller and PIC microcontroller. The other pair is used for communication between PIC and mobile robot for controlling activities

OBJECTIVE

To find the path and control the motion of mobile robot in the path using IR sensor feed back mechanism. The controlling is done by using mobile.

This system is divided into different modules

- 1) Object detection and angle determination in the path using IR sensor.
- 2) SMS protocol (F-Bus) development.
- 3) Design of RF circuits for data transfer and camera interface.

BLOCK DIAGRAM

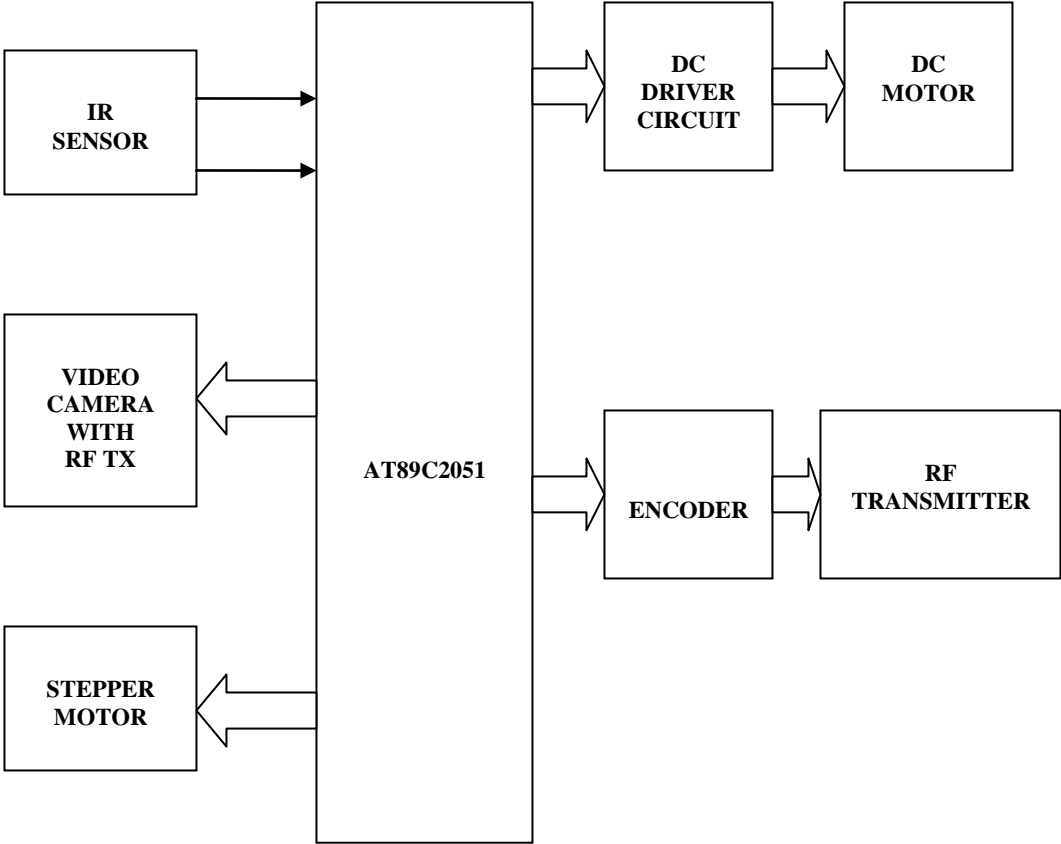

CONTROL CIRCUIT

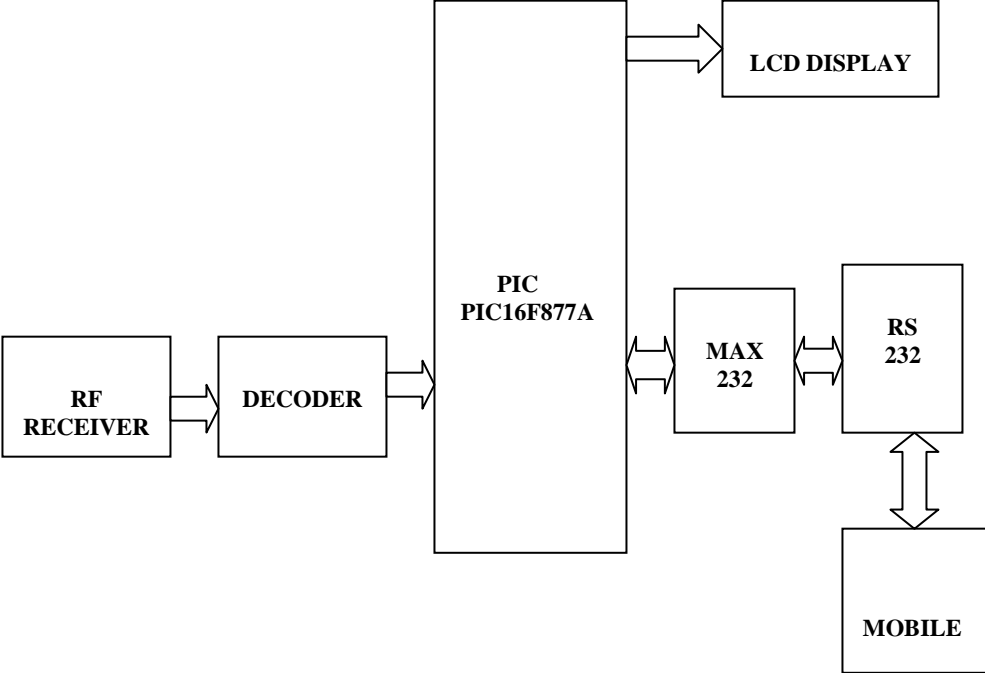

PC WITH RF RECEIVER

