

# Wireless Intelligent Rehabilitation Robotic System For the Disabled and the Elderly

## Abstract:-

KARES (KA1ST Rehabilitation Engineering System) is a rehabilitation robotic system with 6 degrees of freedom robot arm mounted on the powered wheelchair, in order to assist the disabled and the elderly for the independent livelihood. Human machine interaction is very important in this system. Specially, the direct control of the robot arm takes a high cognitive load on the user part while physically disabled persons may have difficulties operating joysticks or push buttons for delicate movements. Therefore, a certain degree of autonomy of the robotic system is needed. To perceive the environment, color vision and force/torque sensors are mounted on the end-effector of the robotic arm of KARES. Four basic tasks are tested; picking up a cup on the table, picking up a pen on the floor, moving the object to the user's face, and operating a switch on a wall. These tasks are performed autonomously in the semi-structured environment.

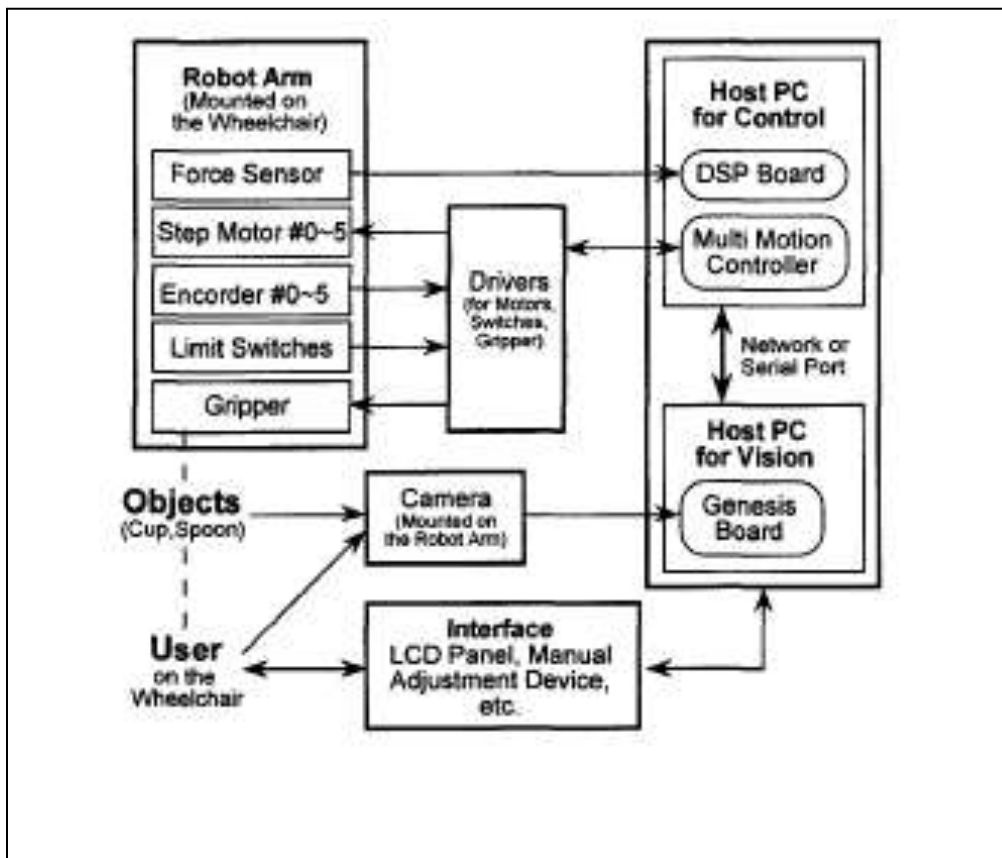

Overall  
diagram of

block  
KARES :

**Block Diagram of PC Control and Video Receiving Systems**

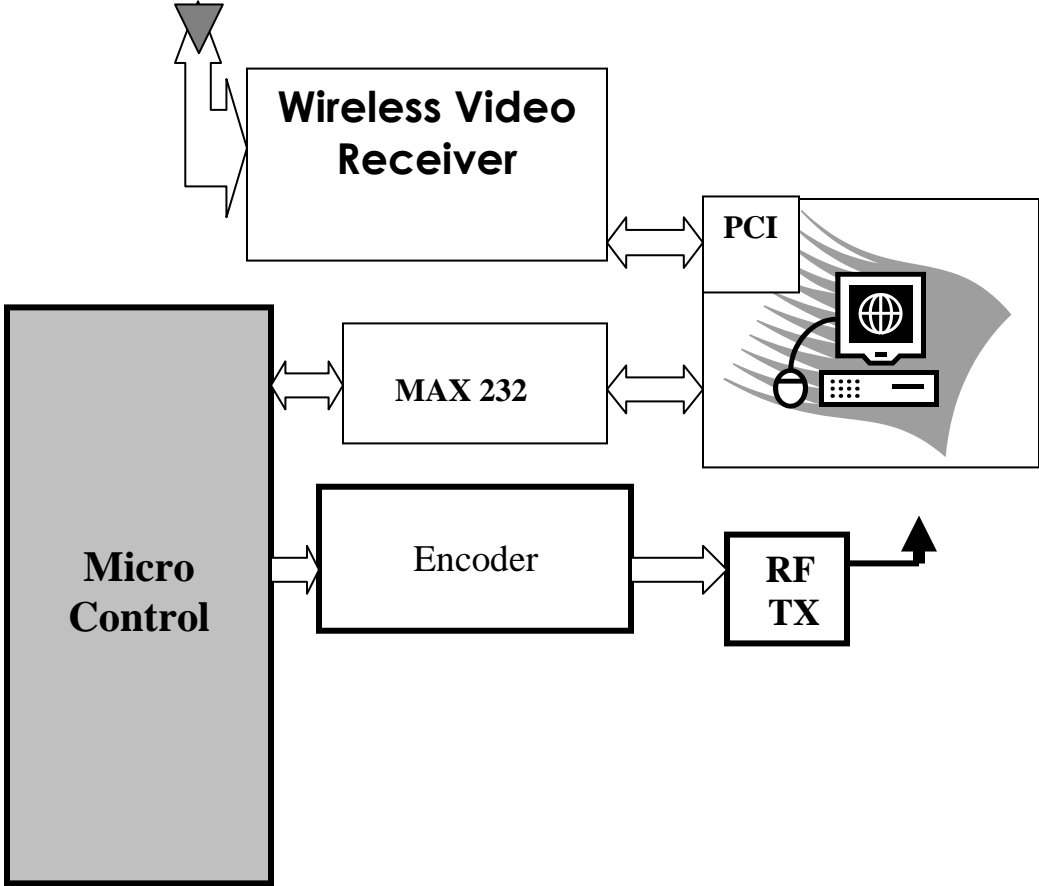

# Block Diagram of Wheel Chair Interface Circuits

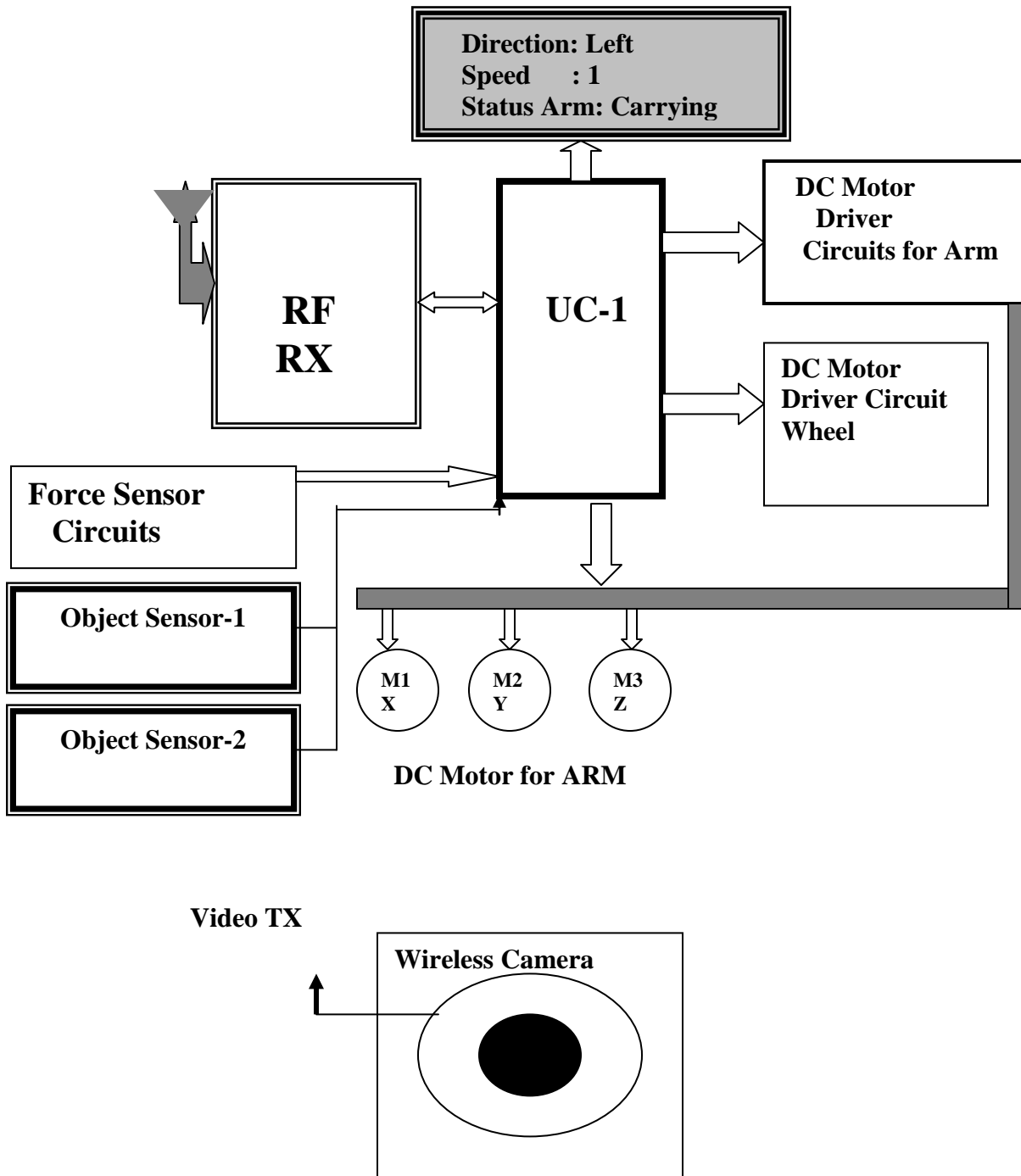

To recognize environment, two sensors, i. e., vision and force/torque sensors are equipped. JAI-1050 color **CCD** camera is used as the vision sensor. This camera can be easily mounted on the robot end-effector for small size (12" in diameter) with a remote head type. To process vision information, Genesis board (MATROX) is used. JR3 (50M31, **140g**, 50" in diameter, and 31" in thickness) is used as the **6** degrees of freedom force/torque sensor. For the manual control of the robotic arm, 6 degrees of freedom input device with 10 keys (space ball 2003) is mounted upon the side of a wheelchair. In addition, simple voice commands are enable to operate the robotic arm.

### *C. Mechanical Design of the Robotic Arm*

In the design of the robotic arm, many factors are considered, i. e. the weight, the easiness to assemble and analysis, workspace, load capacity, speed, repeatability and accuracy, the volume, the energy efficiency, and the cost. In case of the robotic arm that is mounted on the wheelchair, a light arm relative to the workstation-based robotic arm is needed to navigate around the wheelchair. Therefore, the design of the robotic arm should be focused on its weight. Other factam considered are easiness of exchange, assembly, and analysis of parts. The maximum payload is 500g. This is selected in consideration of a cup of water without weight of sensors. The length of the robotic arm is 82cm in consideration of body size of Korean people. Three types of axis configuration of the arm are examined; the front side mounted type, the up side mounted type, and the left or right side mounted type. In consideration of the parking pose and the torque that is required in motions of the arm, the front side mounted type is selected. In the robotic arm, revolutionary joints with differential gears are designed. These joints have 2 times efficiency in the maximum. Worm gears and differential gears are used to reduce velocity. The position of motors is located on the bottom of a link. For actuators, stepping motors are chosen for the cost and the easiness of the control. The material of the arm is aluminum (A1606 1) for light weight. (c) Moving **an** object to the user's face. (d) Operating a switch on a wall.